



PEM® concealed-head self-clinching studs and standoffs install permanently and promote smooth designs.



CH™

**CONCEALED-HEAD
SELF-CLINCHING
STUDS AND STANDOFFS**

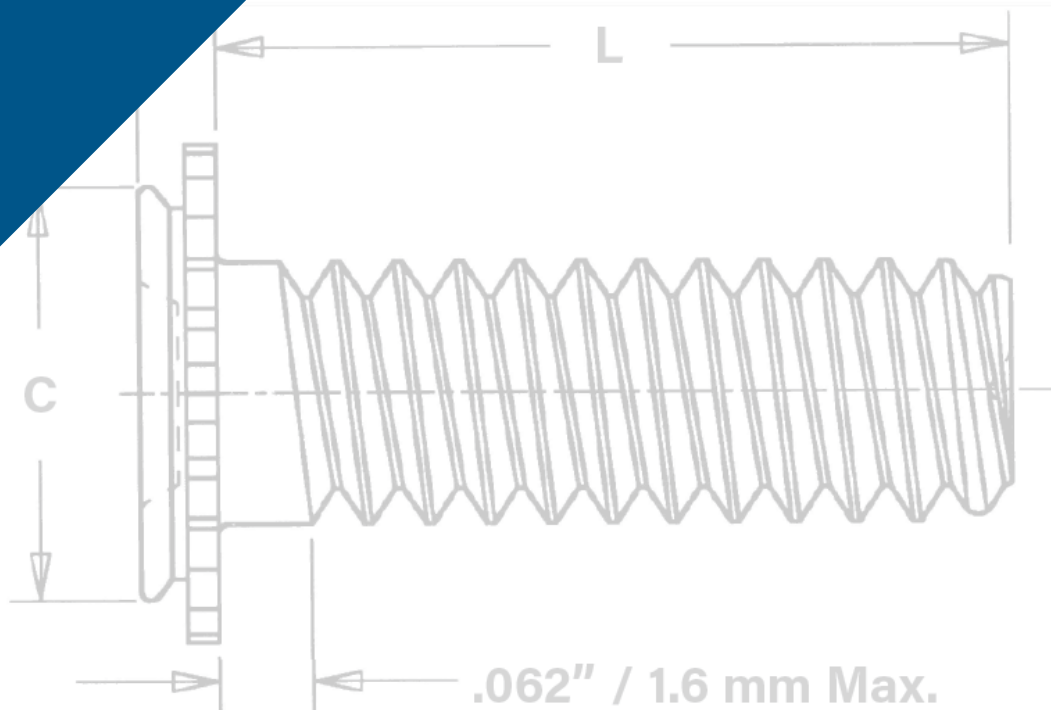

CONCEALED-HEAD SELF-CLINCHING STUDS AND STANDOFFS

Concealed-head self-clinching studs and standoffs install permanently and promote smooth designs:

- Install permanently in steel or aluminum sheets as thin as .062" / 1.6 mm to provide strong and reusable threads for mating hardware in a wide range of assembly applications.
- Allow the side of the sheet opposite installation to remain smooth and unmarred.
- One side installation additionally serves to satisfy strict ingress protection (IP) requirements where the sheet must remain completely sealed from air, liquid, dust, gases or other potentially infiltrating elements.
- Only require a blind milled hole to the recommended size and minimum depth.
- Install using a PEMSERTER® press or other standard press.
- CFHC™ studs can be ordered to NAS63540/4 specifications.⁽¹⁾

(1) To meet national aerospace standards and to obtain testing documentation, Type CFHC studs must be ordered using appropriate NAS63540/4 part number. Check our web site for a complete Military Specification and National Aerospace Standards Reference Guide (Bulletin NASM).



Concealed-head Stud



Concealed-head Standoff

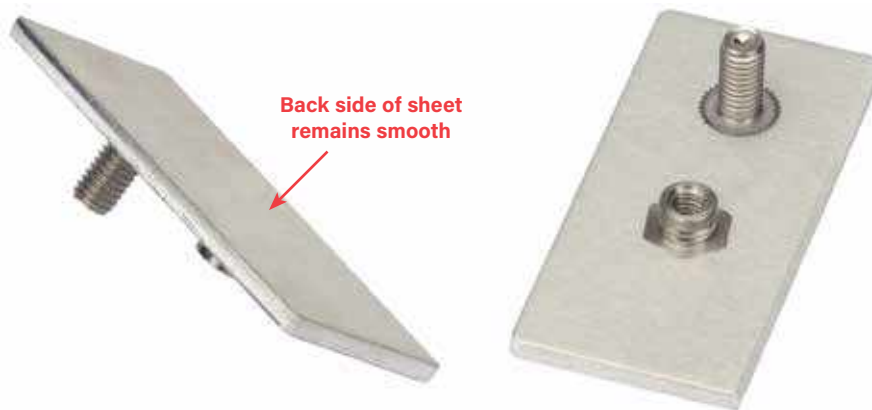

CONCEALED-HEAD SELF-CLINCHING STUDS AND STANDOFFS

CHA™, CFHA™, CHC™ AND CFHC™ ALUMINUM AND STAINLESS STEEL STUDS

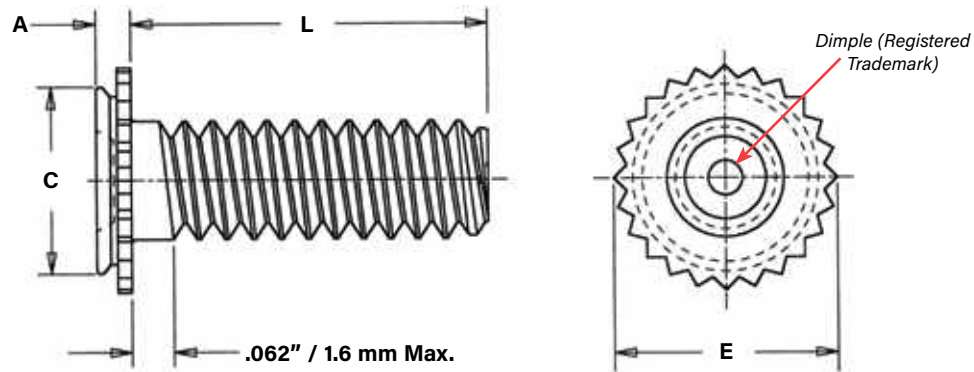

Clinching profile may vary.

All dimensions are in inches.

UNIFIED	Thread Size (#4-40)	Type		Thread Code	Length Code "L" ±.015 (Length code is in 16ths of an inch)						Min. Sheet Thickness	Blind Mounting Hole Dia. +.003 -0.000	Min. Depth of Blind Hole (1)	A (Shank) Max.	E ±.010	C Max.	Min. Dist. Hole To Edge	Max. Hole In Attached Parts
		Aluminum	Stainless Steel		.250	.375	.500	.625	.750	1.00								
		.112-40 (#4-40)	CHA		CHC	440	4	6	8	10								
.138-32 (#6-32)	CHA	CHC	632	4	6	8	10	12	16	.062 .093	.213	.043 .075	.041 .071	.250	.212	.188	.160	
.164-32 (#8-32)	CHA	CHC	832	4	6	8	10	12	16	.062 .093	.290	.043 .075	.041 .071	.328	.289	.219	.185	
.190-32 (#10-32)	CHA	CHC	032	—	6	8	10	12	16	.062 .093	.312	.043 .075	.041 .071	.350	.311	.250	.210	

All dimensions are in millimeters.

METRIC	Thread Size x Pitch	Type		Thread Code	Length Code "L" ±0.4 (Length code is in millimeters)						Min. Sheet Thickness	Blind Mounting Hole Dia. +0.08	Min. Depth of Blind Hole (1)	A (Shank) Max.	E ±0.25	C Max.	Min. Dist. Hole To Edge	Max. Hole In Attached Parts
		Aluminum	Stainless Steel		6	8	10	12	16	20								
		M3 x 0.5	CHA		CHC	M3	6	8	10	12								
M4 x 0.7	CHA	CHC	M4	6	8	10	12	16	20	25	1.6 2.4	7.37	1.1 1.91	1.04 1.8	8.33	7.35	5.6	4.6
M5 x 0.8	CHA	CHC	M5	—	—	10	12	16	20	25	1.6 2.4	7.93	1.1 1.91	1.04 1.8	8.89	7.9	6.4	5.6

(1) Blind holes may be deeper than minimums except where sheet material is at or near minimum thickness. Fasteners should always be installed so the flange is flush with the surface of the sheet.

PART NUMBER DESIGNATION

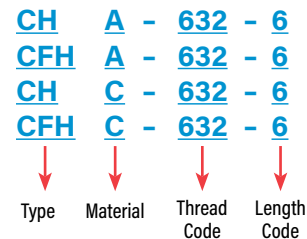

CONCEALED-HEAD SELF-CLINCHING STUDS AND STANDOFFS

CSS™ AND CSOS™ STAINLESS STEEL STANDOFFS

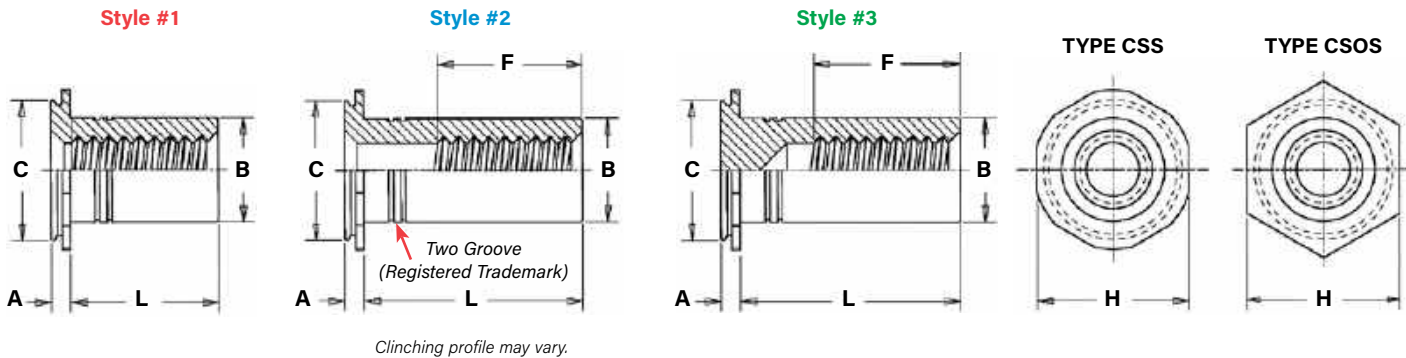

All dimensions are in inches.

UNIFIED	Thread Size	Type	Thread Code	Length Code "L" +.002 -.005 (Length code is in 16ths of an inch)							Min. Sheet Thickness	Blind Mounting Hole Dia. +.003 -.000	Min. Depth of Blind Hole (4)	Min. Depth Full Thread F	A (Shank) Max.	B Max. (5)	C Max.	H Nom.	Min. Dist. Hole \varnothing To Edge	
		Stainless Steel		.187	.250	.312	.375	.500	.625	.750										1.00
		.112-40 (#4-40)	CSS	440	3 ⁽¹⁾	4 ⁽²⁾	5 ⁽²⁾	6 ⁽²⁾	8 ⁽³⁾	10 ⁽³⁾	12 ⁽³⁾	16 ⁽³⁾	.062	.213	.043	.188	.041	.165	.212	.250
		CSOS										.093	.075		.072					
	.138-32 (#6-32)	CSS	632	3 ⁽¹⁾	4 ⁽¹⁾	5 ⁽²⁾	6 ⁽²⁾	8 ⁽³⁾	10 ⁽³⁾	12 ⁽³⁾	16 ⁽³⁾	.062	.290	.043	.250	.041	.213	.289	.312	.219
		CSOS										.093		.075		.072				
	.164-32 (#8-32)	CSS	832	3 ⁽¹⁾	4 ⁽¹⁾	5 ⁽²⁾	6 ⁽²⁾	8 ⁽³⁾	10 ⁽³⁾	12 ⁽³⁾	16 ⁽³⁾	.062	.312	.043	.250	.041	.245	.311	.344	.250
		CSOS										.093		.075		.072				
	.190-32 (#10-32)	CSS	032	3 ⁽¹⁾	4 ⁽¹⁾	5 ⁽¹⁾	6 ⁽¹⁾	8 ⁽²⁾	10 ⁽³⁾	12 ⁽³⁾	16 ⁽³⁾	.062	.344	.043	.375	.041	.290	.343	.375	.281
		CSOS										.093		.075		.072				
	.250-20 (1/4-20)	CSS	0420	3 ⁽¹⁾	4 ⁽¹⁾	5 ⁽¹⁾	6 ⁽¹⁾	8 ⁽²⁾	10 ⁽²⁾	12 ⁽³⁾	16 ⁽³⁾	.062	.390	.043	.375	.041	.354	.389	.438	.375
		CSOS										.093		.075		.072				

All dimensions are in millimeters.

METRIC	Thread Size x Pitch	Type	Thread Code	Length Code "L" +0.05 -0.13 (Length code is in millimeters)							Min. Sheet Thickness	Blind Mounting Hole Diameter +0.08	Min. Depth of Blind Hole (4)	Min. Depth Full Thread F	A (Shank) Max.	B Max. (5)	C Max.	H Nom.	Min. Dist. Hole \varnothing To Edge	
		Stainless Steel		4 ⁽¹⁾	6 ⁽¹⁾	8 ⁽²⁾	10 ⁽³⁾	12 ⁽³⁾	16 ⁽³⁾	20 ⁽³⁾										25 ⁽³⁾
		M3 x 0.5	CSS	M3	4 ⁽¹⁾	6 ⁽¹⁾	8 ⁽²⁾	10 ⁽³⁾	12 ⁽³⁾	16 ⁽³⁾	20 ⁽³⁾	25 ⁽³⁾	1.6	5.41	1.1	5	1.04	4.2	5.39	6.35
		CSOS				8 ⁽³⁾						2.4	1.91		1.83					
	M4 x 0.7	CSS	M4	4 ⁽¹⁾	6 ⁽¹⁾	8 ⁽²⁾	10 ⁽²⁾	12 ⁽³⁾	16 ⁽³⁾	20 ⁽³⁾	25 ⁽³⁾	1.6	7.92	1.1	6.5	1.04	6.23	7.9	8.74	6.4
		CSOS					10 ⁽³⁾					2.4		1.91		1.83				
	M5 x 0.8	CSS	M5	4 ⁽¹⁾	6 ⁽¹⁾	8 ⁽¹⁾	10 ⁽²⁾	12 ⁽²⁾	16 ⁽³⁾	20 ⁽³⁾	25 ⁽³⁾	1.6	8.74	1.1	9.6	1.04	7.37	8.72	9.53	7.2
		CSOS										2.4		1.91		1.83				
	M6 x 1	CSOS	M6	4 ⁽¹⁾	6 ⁽¹⁾	8 ⁽¹⁾	10 ⁽²⁾	12 ⁽²⁾	16 ⁽³⁾	20 ⁽³⁾	25 ⁽³⁾	2.4	9.9	1.91	9.6	1.83	9	9.89	11.11	9.5

- Style #1.** Minimum thread length is equal to barrel length "L". Screw might not pass through shank end. Screws with lengths exceeding "L" should not be used or they may cause "jacking-out" of standoff from the sheet.
- Style #2.** Screw might not pass through unthreaded end. Screws with lengths exceeding "L" should not be used or they may cause "jacking-out" of standoff from the sheet.
- Style #3.** Blind.
- Blind mounting holes may be deeper than minimums except where sheet material is at or near minimum thickness. Fasteners should always be installed so the flange is flush with the surface of the sheet.
- If standoff is used as a bushing, the hole in attached part must not exceed "B" plus .020" / 0.51 mm.

PART NUMBER DESIGNATION

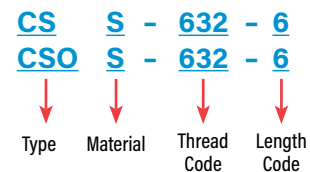

CONCEALED-HEAD SELF-CLINCHING STUDS AND STANDOFFS

MATERIAL AND FINISH SPECIFICATIONS

Type	Threads		Fastener Materials		Finish		For Use In Sheet Hardness (1)	
	External, ASME B1.1 2A / ASME B1.13M, 6g	Internal, ASME B1.1 2B / ASME B1.13M, 6H	Aluminum	300 Series Stainless Steel	No Finish	Passivated and/or tested per ASTM A380	HRB 70 / HB 125 or Less	HRB 50 / HB 89 or Less
CHA
CFHA
CHC	
CFHC	
CSS		
CSOS		

(1) HRB - Hardness Rockwell "B" Scale. HB - Hardness Brinell.

INSTALLATION

1. Mill a round blind hole to the correct minimum depth.*
2. Place fastener into anvil hole.
3. Place the mounting hole over the shank of the fastener.
4. With punch and anvil surfaces parallel, apply squeezing force until the flange is flush with the mounting sheet.

* End mills available from PennEngineering. See chart below.

INSTALLATION NOTES

- For best results we recommend using a PEMSERTER® press for installation of PEM self-clinching fasteners. Please check our website for more information.
- Visit the Animation Library on our website to view the installation process [for select products](#).

END MILL INFORMATION

Double-ended, two-flute H.S.S. center-cutting end mills are available from stock.

PennEngineering does not manufacture center-cutting end mills, but we do keep a supply in stock for your convenience.



Thread Code	Fastener Type	Required Size End Mill	PEM Part No.
440, M3	CFHC, CHC, CFHA, CHA Studs	.172"	CHM-172
	CSOS, CSS Standoffs	.213"	CHM-213
632	CFHC, CHC, CFHA, CHA Studs	.213"	CHM-213
	CSOS, CSS Standoffs	.290"	CHM-290
832, M4	CFHC, CHC, CFHA, CHA Studs	.290"	CHM-290
	CSOS, CSS Standoffs	.312"	CHM-312
032, M5	CFHC, CHC, CFHA, CHA Studs	.312"	CHM-312
	CSOS, CSS Standoffs	.344"	CHM-344
0420, M6	CSOS Standoffs	.390"	CHM-390

CFHA, CFHC, CHC, CHA
Concealed-head studs

CSOS, CSS
Concealed-head standoffs

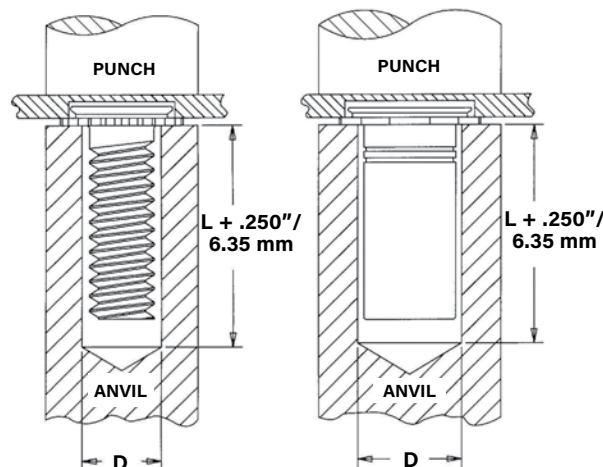

PEMSERTER® Installation Tooling

All dimensions are in inches.

UNIFIED	Type	Thread Code	D +.003 -.000	Punch Part Number	Anvil Part Number
	CHA / CHC / CFHA / CFHC	440	.127	975200048	97020006300
	CHA / CHC / CFHA / CFHC	632	.139	975200048	970200007300
	CHA / CHC / CFHA / CFHC	832	.179	975200048	970200008300
	CHA / CHC / CFHA / CFHC	032	.205	975200048	970200009300
	CSS / CSOS	440	.170	975200048	970200014300
	CSS / CSOS	632	.218	975200048	970200015300
	CSS / CSOS	832	.250	975200048	970200016300
	CSS / CSOS	032	.295	975200048	970200017300
	CSS / CSOS	0420	.358	975200048	970200018300

All dimensions are in millimeters.

METRIC	Type	Thread Code	D +0.08	Punch Part Number	Anvil Part Number
	CHA / CHC / CFHA / CFHC	M3	3.4	975200048	970200229300
	CHA / CHC / CFHA / CFHC	M4	4.4	975200048	970200019300
	CHA / CHC / CFHA / CFHC	M5	5.4	975200048	970200020300
	CSS / CSOS	M3	4.33	975200048	970200014300
	CSS / CSOS	M4	6.36	975200048	970200016300
	CSS / CSOS	M5	7.5	975200048	970200017300
	CSS / CSOS	M6	9.13	975200048	970200018300



CONCEALED-HEAD SELF-CLINCHING STUDS AND STANDOFFS

PERFORMANCE DATA⁽¹⁾

Type	Thread Code	Max. Tightening Torque Ref. (in. lbs.)	Test Sheet Material			
			Cold-rolled Steel		5052-H34 Aluminum	
			Installation (lbs.)	Pullout (lbs.)	Installation (lbs.)	Pullout (lbs.)
Concealed-head Standoffs						
CSS	440	4.75	4,000	300	2,800	200
	632	8.75	4,500	350	3,000	240
	832	18	4,800	400	4,000	270
	032	32	5,500	450	5,000	290
CSOS	440	4.75	4,300	330	2,900	220
	632	8.75	5,000	360	3,200	240
	832	18	5,300	440	4,000	300
	032	32	6,000	600	5,000	400
	0420	64	6,500	650	5,500	430
Concealed-head Studs						
CHC	440	4.75	1,800	240	1,400	130
	632	8.75	2,500	260	1,800	160
	832	18	4,000	270	2,800	180
	032	32	5,000	290	4,000	210
CFHC	440	4.75	2,000	240	1,500	200
	632	8.75	2,700	350	2,500	260
	832	18	3,300	440	3,000	310
	032	32	4,000	680	3,500	360
CHA	440	2.85	(2)	(2)	1,400	125
	632	5.4	(2)	(2)	1,800	135
	832	10.8	(2)	(2)	2,800	145
	032	19.2	(2)	(2)	4,000	170
CFHA	440	2.85	(2)	(2)	1,500	190
	632	5.4	(2)	(2)	2,500	220
	832	10.8	(2)	(2)	3,000	240
	032	19.2	(2)	(2)	3,500	300

Type	Thread Code	Max. Tightening Torque Ref. (N-m)	Test Sheet Material			
			Cold-rolled steel		5052-H34 Aluminum	
			Installation (kN)	Pullout (N)	Installation (kN)	Pullout (N)
Concealed-head Standoffs						
CSS	M3	0.55	17.8	1330	12.5	890
	M4	2	21.3	1775	17.8	1200
	M5	3.6	24.5	2000	22.2	1290
CSOS	M3	.55	19.2	1465	12.9	975
	M4	2	23.6	1955	17.8	1335
	M5	3.6	26.7	2665	22.2	1775
	M6	7.2	28.9	2860	24.4	1915
Concealed-head Studs						
CHC	M3	0.55	8	1065	6.2	575
	M4	2	17.8	1200	12.5	800
	M5	3.6	22.2	1290	17.8	930
CFHC	M3	0.55	8.9	1065	6.7	890
	M4	2	14.7	1955	13.3	1375
	M5	3.6	17.8	3020	15.6	1600
CHA	M3	0.3	(2)	(2)	6.2	555
	M4	1.2	(2)	(2)	12.5	645
	M5	2.16	(2)	(2)	17.8	755
CFHA	M3	0.3	(2)	(2)	6.7	845
	M4	1.2	(2)	(2)	13.3	1065
	M5	2.16	(2)	(2)	15.6	1330

(1) **Published installation forces are for general reference. Actual set-up and confirmation of complete installation should be made by observing proper seating of fastener as described in the installation steps. Other performance values reported are averages when all proper installation parameters and procedures are followed. Variations in mounting hole size, sheet material, and installation procedure may affect performance. Performance testing this product in your application is recommended. We will be happy to provide technical assistance and/or samples for this purpose.**

(2) Not recommended.

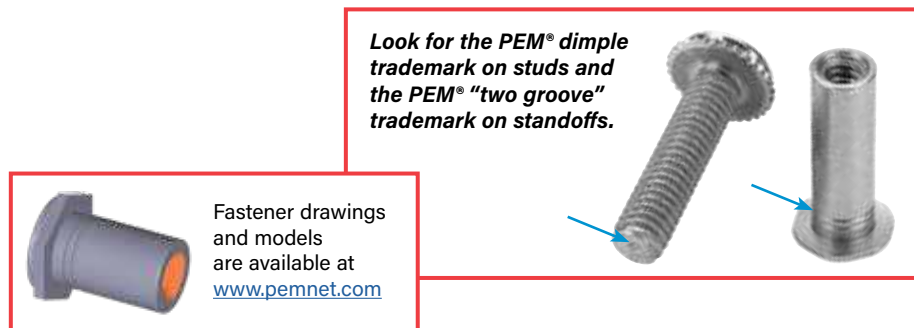

All PEM® products meet our stringent quality standards. If you require additional industry or other specific [quality certifications](#), special procedures and/or part numbers are required. Please contact your local sales office or representative for further information.

Regulatory [compliance information](#) is available in Technical Support section of our website. Specifications subject to change without notice. See our website for the most current version of this bulletin.

PennEngineering®



North America: Danboro, Pennsylvania USA • E-mail: info@pemnet.com • Tel: +1-215-766-8853 • 800-237-4736 (USA)

Europe: Galway, Ireland • E-mail: europa@pemnet.com • Tel: +353-91-751714

Asia/Pacific: Singapore • E-mail: singapore@pemnet.com • Tel: +65-6-745-0660

Shanghai, China • E-mail: china@pemnet.com • Tel: +86-21-5868-3688

Visit our PEMNET™ Resource Center at www.pemnet.com • Technical support e-mail: techsupport@pemnet.com