

Original Instruction Manual for Differential Pressure Transmitter P26



halstrup-walcher GmbH

Stegener Straße 10
D-79199 Kirchzarten

Phone: +49 (0) 76 61/39 63-0
Fax: +49 (0) 76 61/39 63-99

Email: info@halstrup-walcher.de
Internet: www.halstrup-walcher.de

Version overview

Version:	Date:	Author:	Amendments:
	07/2008	Sie	Initial version
A	03/2009	Ka	New RS232-commands
B	10/2010	Ze	Update Connection diagram
C	01/2016	Me	Update menu tree
D	03/2016	Me	Measuring accuracy
E	05/2017	Me	Measuring accuracy; conformity, hysteresis
F	08/2018	Me	Mounting instructions chapter 2.2
G	08/2018	Me	Special version with SW 4.01
H	03/2019	Ka	Internal RS232 as standard
J	07/2019	Me	Certifications CE, CSA
K	03/2020	Me	External zero-point calibration only at 24VDC
L	10/2020	Ka	Formulas in chapter 3.5
M	11/2020	Me	Signal ranges of the output signals
N	10/2022	Me	Technical data update; version overview; QR code added

© 2022

The manufacturer owns the copyright to this instruction manual. It contains technical data, instructions and drawings detailing the device's features and how to use them. It must not be copied either wholly or in part or made available to third parties.

The instruction manual is part of the product. Please read this manual carefully, follow our instructions, and pay special attention to the safety information provided. This instruction manual should be available at all times. Please contact the manufacturer if you do not understand any part of the instructions.

The manufacturer reserves the right to continue developing this device model without documenting such development in each individual case. The manufacturer will be happy to determine whether this manual is up-to-date.

Table of Content:

1 Purpose of instruction manual	5
2 Safety precautions	6
2.1 Appropriate use	6
2.2 Shipping, assembly, electrical connections and start-up	6
2.3 Troubleshooting, maintenance, repairs, disposal	7
2.4 Symbols	7
3 Instrument description	8
3.1 Functions	8
3.2 User interfaces	9
3.3 Internal connections and buttons	10
3.4 Front view	13
3.5 Readout of volume, mass flow, flow velocity	14
4 Zero-point calibration cycle	15
4.1 External zero-point calibration (optional)	15
5 Overpressure protection	15
6 Display (optional)	15
7 Menu (optional)	16
7.1 Display	16
7.2 Scale	16
7.2.1 Pressure	17
7.2.1.1 Top	17
7.2.1.2 Bottom	17
7.2.1.3 Units	17
7.2.2 Volume flow	17
7.2.2.1 Value	18
7.2.2.2 Units	18
7.2.3 Mass flow	18
7.2.3.1 Value	18
7.2.3.2 Units	18
7.2.4 Flow rate	18
7.2.4.1 Value	18
7.2.4.2 Units	18
7.3 Air consumption function (option available from firmware version 3.0)	19
7.3.1 Mode	19
7.3.1.1 Off	19
7.3.1.2 $\Sigma(\Delta P > 0)$	19
7.3.1.3 $\Sigma(\Delta P)$	19
7.3.1.4 $\Sigma(\text{abs } \Delta P)$	19
7.3.2 Mass/Pulse or Vol./Pulse	20
7.3.3 Pulse output	20
7.3.3.1 Pulse length	20
7.3.3.2 Pulse interval	20
7.3.4 Filter	20
7.3.5 Reset sum	20
7.3.6 Old sum	20
7.3.7 Recall Sum	20
7.3.8 Security code	20

7.4 Warning.....	21
7.4.1 Mode.....	21
7.4.2 Value	21
7.4.3 Hysteresis.....	21
7.4.4 Tv delay time	21
7.4.5 Tn stopping time (from Rev2.11).....	22
7.4.6 Warning signal	22
7.4.7 Filter(from Rev2.14)	22
7.5 Setting.....	22
7.5.1 Language.....	23
7.5.2 Output.....	23
7.5.3 Filter.....	23
7.5.4 Touchtone.....	23
7.5.5 Resolution.....	23
7.5.6 Zeroing	23
7.5.7 SMU (creep suppression)	23
7.5.8 Illumination.....	24
7.5.9 Colour change	24
7.5.10 Brightness.....	24
7.5.11 Contrast	24
7.5.12 Read factory settings	24
7.5.13 Code?	24
7.6 Operation	24
8 Interfaces	25
8.1 USB port (optional).....	25
8.2 Serial interface (via internal connector)	25
8.3 List of commands	26
9 Technical data	29
10 Troubleshooting	30
11 Dimension drawing	31
12 Menu tree	32
13 Certificate of Conformity.....	35

1 Purpose of instruction manual

This instruction manual describes the features of the P26 and provides guidelines for its use. Improper use of this instrument or failure to follow these instructions may cause injury or equipment damage. Every person who uses this device must therefore read the manual and understand the possible risks. The instruction manual, and in particular the safety precautions contained therein, must be followed carefully.

Contact the manufacturer if you do not understand any part of this instruction manual.

Handle this manual with care:

- It must be readily available throughout the lifecycle of the instrument.
- It must be provided to any individuals who assume responsibility for operating the instrument at a later date.
- It must include any supplementary materials provided by the manufacturer.

The manufacturer reserves the right to continue developing this instrument model without documenting such development in each individual case. The manufacturer will be happy to determine whether this manual is up-to-date.

Conformity

This device is state of the art.

It complies with the statutory requirements of the EC and UK-directives. This is documented by the CE and the UKCA mark being affixed.



2 Safety precautions

2.1 Appropriate use

The P26 is used to measure pressure, volumetric flow, mass flow and flow rate.

Always observe the operating requirements – particularly the permissible supply voltage – indicated on the rating plate and in the “Technical data” section of this manual.

The instrument may only be handled as indicated in this manual. Modifications to the instrument are prohibited. The manufacturer is not liable for damages caused by improper use or failure to follow these instructions. Violations of this type render all warranty claims null and void.

2.2 Shipping, assembly, electrical connections and start-up

Do not close the pressure inlets during shipping. Changes in barometric pressure may damage devices with low measuring ranges.

Assembly and the electrical connections should only be handled by professionals. They should be given proper training and be authorised by the operator of the facility.

Although the P26 pressure transducer is highly robust, it is nevertheless a precision instrument and should be handled with care. Avoid mounting the P26 in the direct vicinity of any sources of heat or radiation. Ideally, the instrument should be mounted vertically on a wall not subject to vibration.

The instrument may only be operated by appropriately trained individuals who have been authorized by the operator of the facility.

Do not carry out a function test with compressed or breathable air. This would damage instruments with low measuring ranges.

The pressure ports may only be connected and disconnected when the device is switched off.

Measurement errors may occur if the instrument is not kept protected from sunlight. Specific safety precautions are given in individual sections of this manual.

2.3 Troubleshooting, maintenance, repairs, disposal

The individual responsible for the electrical connections must be notified if the instrument is damaged or if errors occur that cannot be corrected as indicated in Section 10.

This individual must take the instrument out of service until the error has been corrected and ensure that it cannot be used unintentionally.

Always unplug the power cord resp. shutdown all supply voltages before opening the instrument!

This instrument requires no maintenance.

Only the manufacturer may perform repairs that require the housing to be opened.

The electronic components of the instrument contain environmentally hazardous materials and materials that can be reused. The instrument must therefore be sent to a recycling plant when you no longer wish to use it. The environment codes of your particular country must be complied with.

2.4 Symbols

The symbols given below are used throughout this manual to indicate instances when improper operation could result in the following hazards:



WARNING! This warns you of a potential hazard that could lead to bodily injury up to and including death if the corresponding instructions are not followed.



WARNING: This warns you of a potential hazard that could lead to significant property damage if corresponding instructions are not followed.



INFORMATION! This indicates that the corresponding information is important for operating the instrument properly.

3 Instrument description

3.1 Functions

The P26 is controlled by a microprocessor and can

- measure pressure and vacuum
- measure differential pressure
- measure volume flow, mass flow and flow rate
- display a measured value
- monitor a variety of threshold parameters

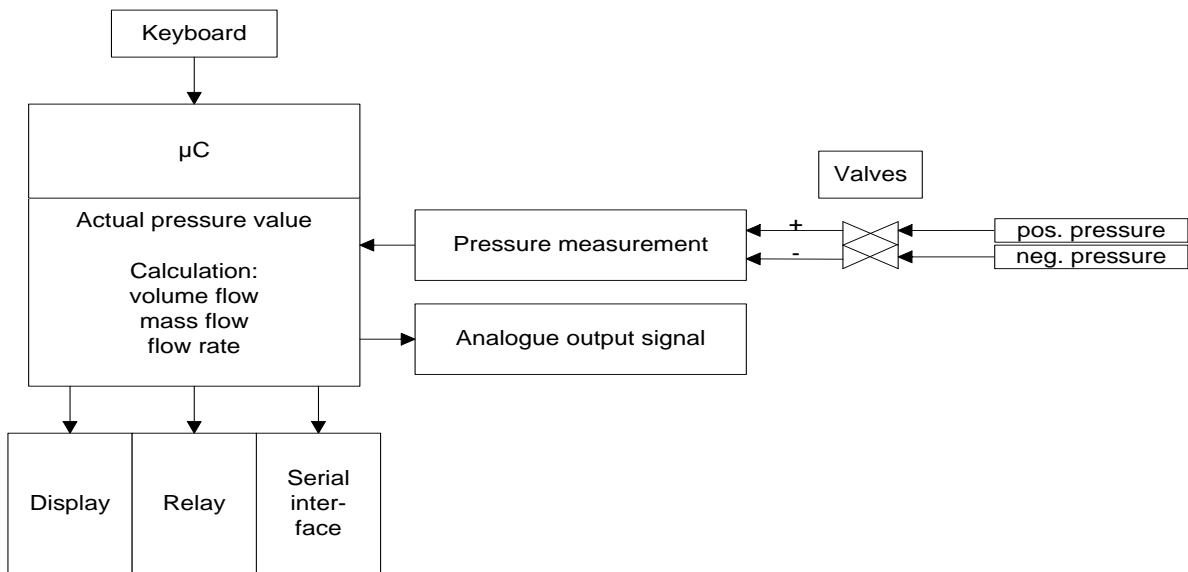

3.2 User interfaces

The following four keys are available:



Menu

UP

Right

Enter

Key	Meaning (Measurement Mode)	Meaning (Menu)
Menu	Start Menu	Go back a menu level
Enter	Start zero-point calibration	Confirm
Up arrow	Max. display	Increases a value or scrolls up
Right arrow	Min. display	Moves the arrow or scrolls down

In measurement mode, the keys perform the following functions:

The Enter key starts a zero-point calibration

▲ - key shows the maximum (to reset: press Enter while the maximum is being displayed)

▶ - key shows the minimum (to reset: press Enter while the minimum is being displayed)

When the air consumption function is activated, the keys perform the following functions:

The Enter key starts a zero-point calibration

Press the "▲" key to display the current mass or volume flow.

Press the "▶" key to display the current value for the operating hours meter.

3.3 Internal connections and buttons

Standard version

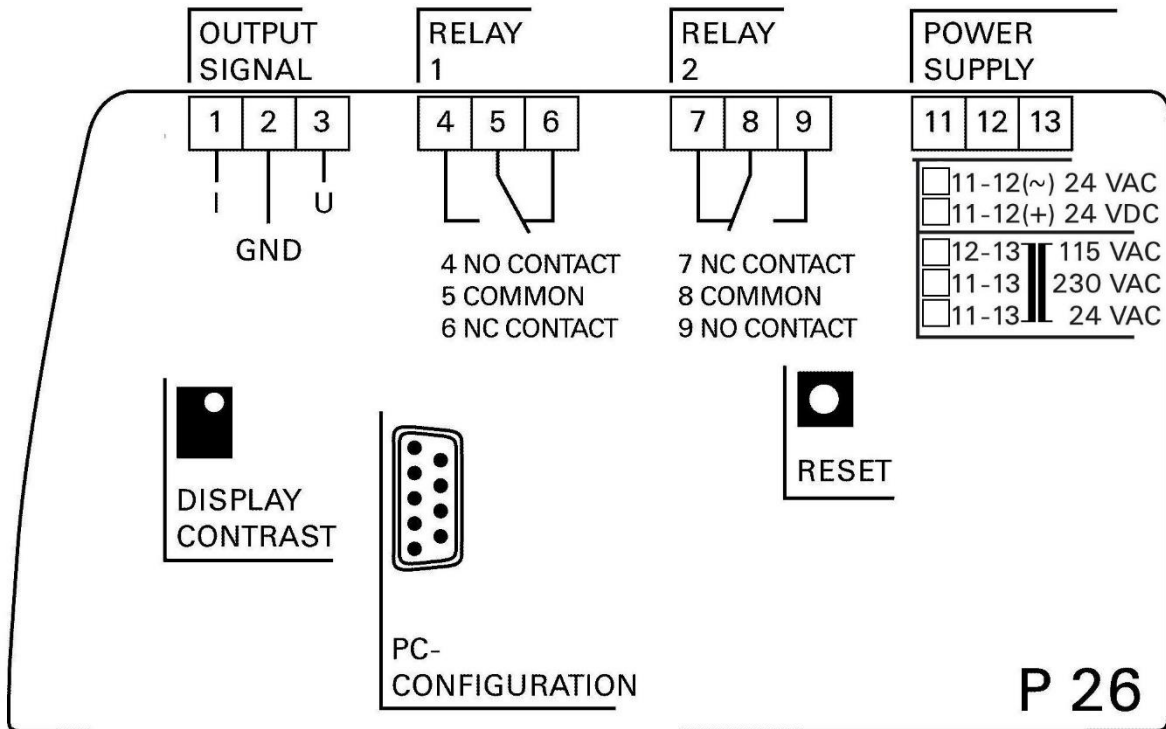

Version with external zero-point calibration

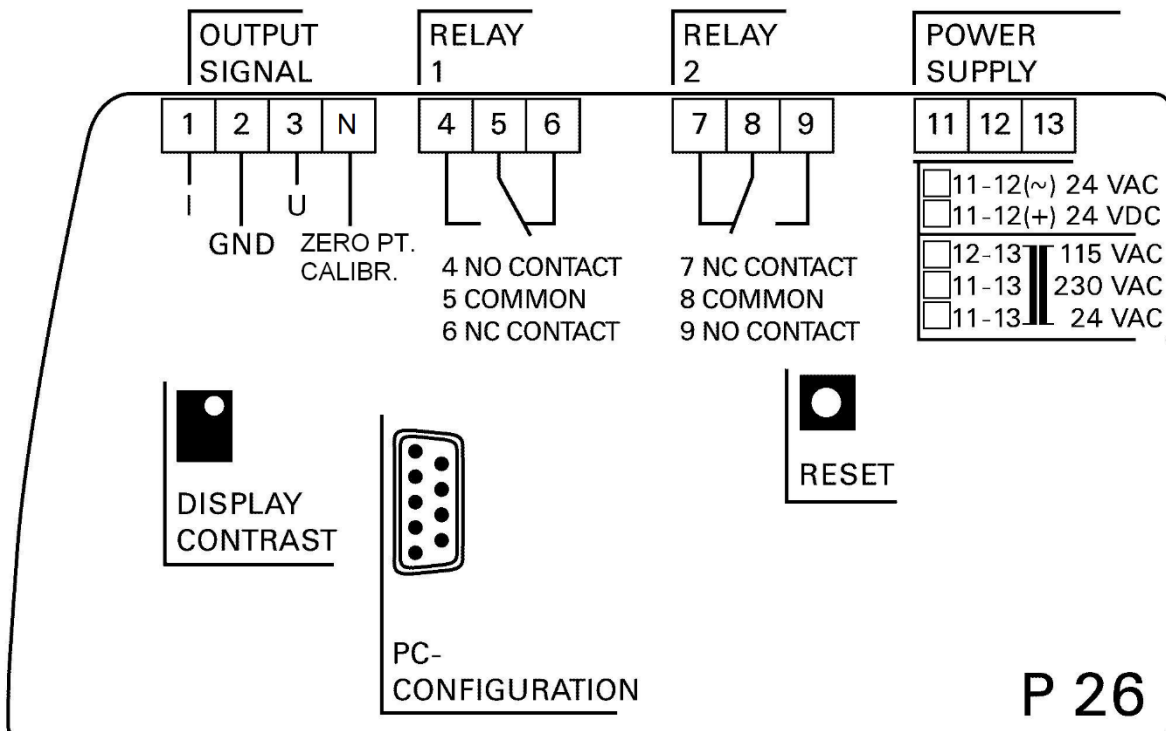

Standard version

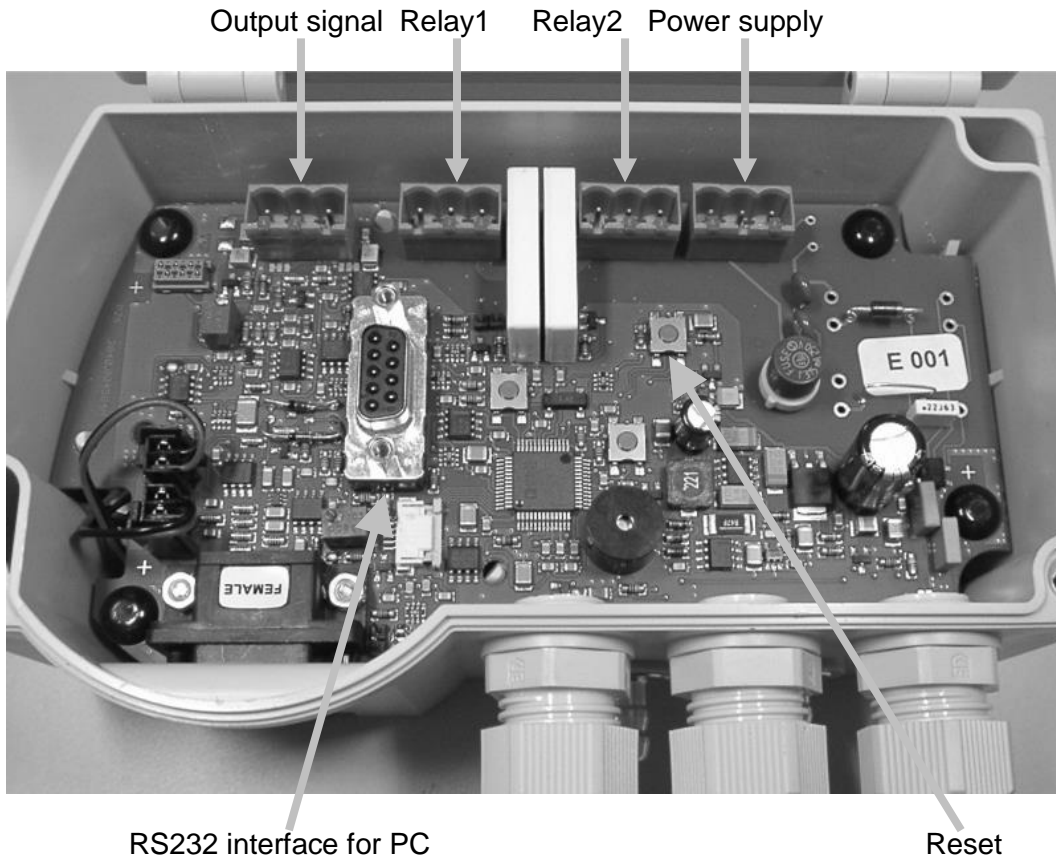

Version with external zero-point calibration

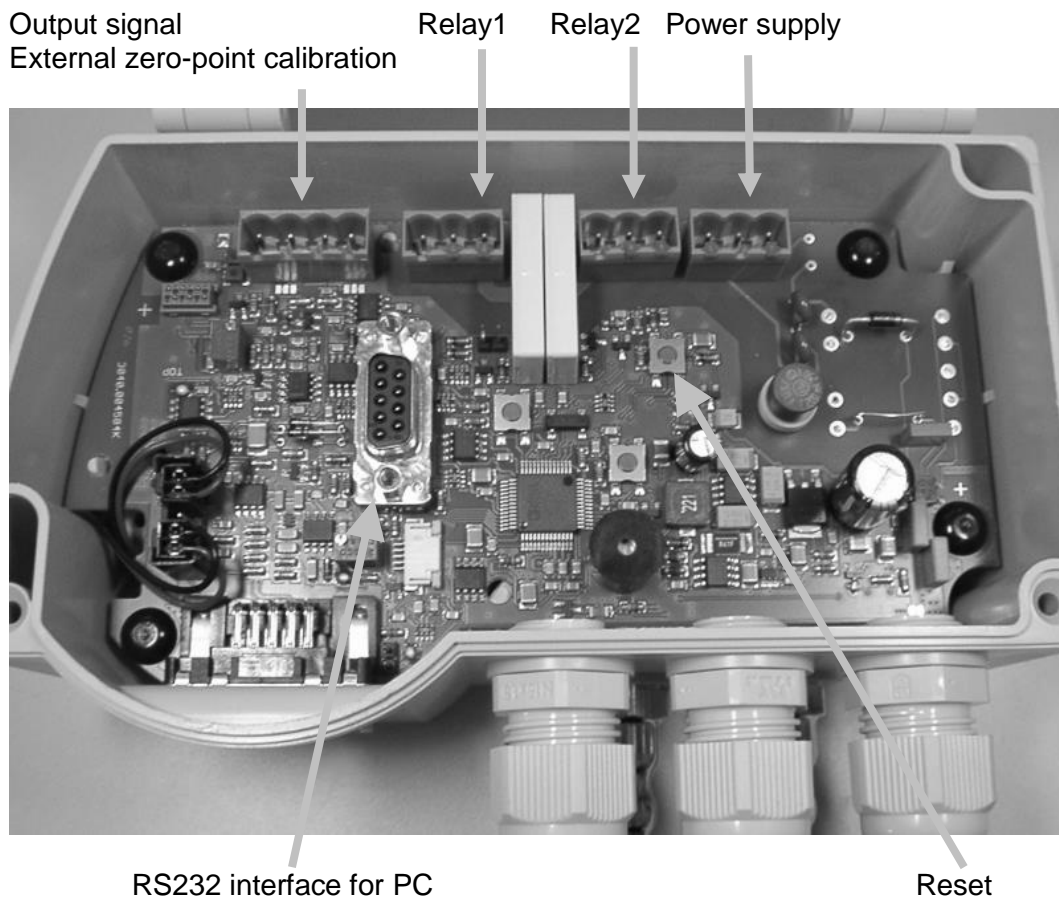

Output signal:

Port designation	Description	Signal range
I	current output 0 ...20 mA current output 4 ...20 mA	0,00 mA...20,75 mA 4,00 mA...20,00 mA
GND	earth	
U	voltage output 0 ...10V voltage output -5V ...+5V	-2,0V...+12,0V -5,0V...+7,0V
N (optional)	+24V starts external zero-point calibration	

- Relay 1:

Port designation	Description
4 CLOSING CONTACT	active position
5 CENTRE CONTACT	middle position
6 OPENING CONTACT	rest position

- Relay 2:

Port designation	Description
7 OPENING CONTACT	rest position
8 CENTRE CONTACT	middle position
9 CLOSING CONTACT	active position

- Power supply:

- 24V DC
Left contact => Ground
Central contact => +24V DC
- 24V AC
Left contact => Ground
Central contact => +24V AC

with transformer

- 115V AC
Central contact and right contact
- 230V AC
Left contact and right contact
- 24V AC
left contact and right contact

- RS232 interface for PC:

RS232 interface for parameter settings

- Reset:

Pressing this button restarts the processor.

3.4 Front view

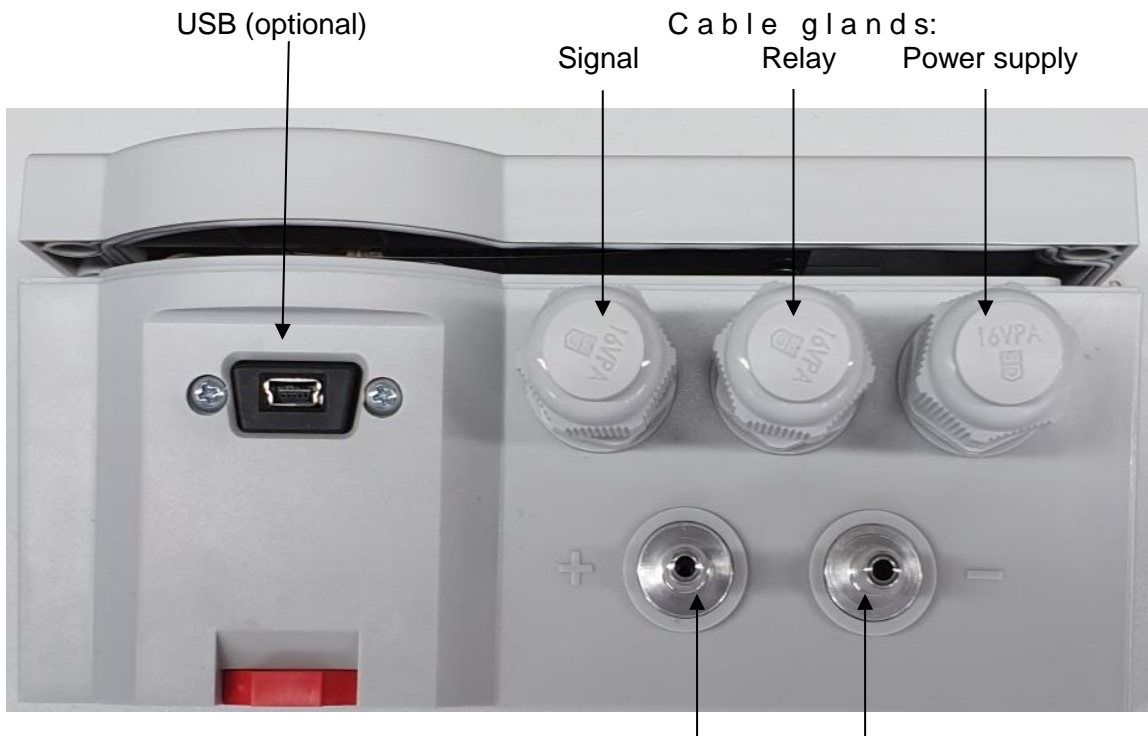

Pressure ports: + -

- RS-232:

Port designation	PIN	Description
RXD	3	receive
TXD	2	send
GND	5	earth

- USB:

Port designation	PIN	Description
Power	1	power supply via USB port of the PC
D- bidirectional	2	USB data, negative polarity
D+ bidirectional	3	USB data, positive polarity
ID	4	not used
Ground	5	GND = USB signal earth
Case Ground	shield	shielding via PC case



INFORMATION!

The greatest possible accuracy is achieved at room temperature (20°C).

3.5 Readout of volume, mass flow, flow velocity

With square-root extracted output signal, the assignment of differential pressure volume, mass flow or flow velocity can be set via the serial interface with a PC software or, for instruments with display, via the menu using the four keys in the top cover.

The calculation of the analogue output and the display (for instruments with display) is done according to the following formulas:

Calculation of the analogue output 0 - 20 mA or 4 - 20 mA:

$$I_{out} = \frac{20 \text{ mA}}{\sqrt{\Delta p_{max}}} \cdot \sqrt{\Delta p} \quad \cdot \quad I_{out} = 4 \text{ mA} + \frac{16 \text{ mA}}{\sqrt{\Delta p_{max}}} \cdot \sqrt{\Delta p}$$

Calculation of the analogue output 0 - 10 V:

$$U_{out} = \frac{10 \text{ V}}{\sqrt{\Delta p_{max}}} \cdot \sqrt{\Delta p}$$

Calculation of the display for volume flow, mass flow or flow velocity:

$$\dot{V} = \frac{\dot{V}_{max}}{\sqrt{\Delta p_{max}}} \cdot \sqrt{\Delta p} \quad \cdot \quad \dot{m} = \frac{\dot{m}_{max}}{\sqrt{\Delta p_{max}}} \cdot \sqrt{\Delta p} \quad \cdot \quad \dot{v} = \frac{\dot{v}_{max}}{\sqrt{\Delta p_{max}}} \cdot \sqrt{\Delta p}$$

Thereby is:

- Δp the (internal) measured value for the differential pressure (in the selected unit, e.g. Pa)
- Δp_{max} the (adjustable) scaling end value of the differential pressure = "Scale Top" (in the selected unit, e.g. Pa).
"Scale Bottom" must always be 0 when the output is square-rooted.
 Δp_{max} , for example, is the differential pressure value generated by a dynamic pressure probe at volume flow \dot{V}_{max}
- I_{out} Analog current output signal (0 - 20 mA or 4 - 20 mA)
- U_{out} Analog voltage output signal (0 - 10 V)
- \dot{V}_{max} the (adjustable) volume flow value to be displayed at a differential pressure of Δp_{max} = "Vol. flow. at max. scaling value" (in the selected unit, e.g. m³/h)
- \dot{V} the displayed volume flow value (in the selected unit, e.g. m³/h)
- \dot{m}_{max} the (adjustable) mass flow value to be displayed at a differential pressure of Δp_{max} = "Mass flow" at max. scaling value" (in the selected unit, e.g. kg/s)
- \dot{m} the displayed mass flow value (in the selected unit, e.g. kg/s)
- \dot{v}_{max} the (adjustable) flow velocity value to be displayed at a differential pressure of Δp_{max} = "Flow rate" at max. scaling value" (in the selected unit, e.g. m/s)
- \dot{v} the displayed flow velocity value (in the selected unit, e.g. m/s)

In addition, a low flow suppression (LFV) can be set as a percentage of the nominal pressure range. If the measured pressure value falls below this limit, the output is set to zero. This avoids strongly fluctuating (square-rooted) output values at very small pressure measuring values.

4 Zero-point calibration cycle

External influences such as temperature, position or ambient pressure can shift the instrument's zero-point, i.e., the value displayed when the pressure ports are open. During calibration, the instrument automatically calculates this shift and takes it into account during the zero-point calibration. The zero-point calibration takes place in two steps, which are shown in the top line of the display (optional).

"→ 0" Measuring signal of the zero-point is being determined.

"→ P" Pressure is being reconfigured

The interval between two zero-point calibrations can be adjusted in the Settings menu. The parameter "AutoNull" can be assigned to values from 0 to 2999 (0= off)

Zero-point calibration can also be started with the Enter key if the device is in Measurement mode.

The P26 does not respond to keys being pressed during calibration.

4.1 External zero-point calibration (optional)

External zero-point calibration is also available (optional). This function is only possible in connection with a supply voltage of 24 VDC. In this version, there is an additional contact on the output connector. To initiate a zero-point calibration, this connection must be connected briefly with +24 V.

INFORMATION!



If a zero-point calibration is initiated via the serial interface or the external zero-point calibration input, this will still be carried out. In this case, it doesn't matter if the zero-point calibration is deactivated or the P26 is in the menu.

5 Overpressure protection

The P26 has an internal overpressure safeguard that protects the precision pressure measurement capsule from damage. (Overload range: 200 x [max. 600 kPa])

6 Display (optional)

The measured values and the menu are shown on the display. The top line is the information line. This line displays the type of measured value or the status of a zero-point calibration. The measured value is displayed in the middle line. If the permitted measuring range is exceeded or not reached, the figures are replaced by '-' characters. The bottom line displays the unit, with the first two digits showing the status of the two relays.

7 Menu (optional)

If the P26 includes a display, you can use the menu to adjust various settings. Press the Menu key to bring up the menu.

In Menu mode, the parent menu item always appears in the top display line. The middle line always shows the current sub-menu item or value to be changed. The bottom line displays units or other help texts.

Start the Menu mode by pressing the "Menu" key. It can be protected with a four-character password. At the main menu level, "Menu" is displayed in the top line and "Display" in the middle line. Select your desired sub-menu by pressing the "▲" and "▶" keys. Press "Enter" to go to a sub-menu or enter a value. Press the "Menu" key to go to the next menu level or to stop entering values.

7.1 Display

The display unit can be selected with this menu item. Press the "▲" and "▶" keys to select the unit you want and press "Enter" to confirm. The type of display (pressure, flow rate etc.) is selected automatically.



When the air consumption function is activated, the selection of units that can be displayed is limited to the following: m³/s, m³/h, ft³/h, kg/s, kg/min or kg/h.

7.2 Scale



The scaling function is not available when the air consumption function is activated. Entering the scaling values defines the density of the medium. Changing these values when the air consumption function is activated will result in the calculation of incorrect totals.

The P26 is usually supplied with standard measuring ranges. You can use the scale to adjust the measuring range for your own use. The output voltage or currents are then copied to this scaled range. The scaled range should always be more than 0.1 times of that of the P26's measuring range, because otherwise the resolution of the outputs and the accuracy will be poorer.

With this menu item, there are 4 sub-menu items:

- Pressure
- Volume flow
- Mass flow
- Flow rate

7.2.1 Pressure

This is an important menu item. It is used to specify the pressure range, which indicates the output value. This pressure range forms the basis for many other settings such as the limits for the relays (warnings) and factors for the flow display.

There are two default settings for the pressure scale:

- Top = Pressure at which the output has its maximum value (e.g. 5V, 10V or 20 mA)
- Bottom – Pressure at which the output has its minimum value (e.g. -5V, 0V, 0mA or 4mA)

Because the values can be freely assigned, settings such as 0V at 0Pa or 10V at -250Pa are also possible.

7.2.1.1 Top

With this menu item, you can set the pressure at which the output will achieve its maximum value. Any value within the measuring range can be selected. It can also be less than the lower scale value.

7.2.1.2 Bottom

With this menu item, you can set the pressure at which the output will achieve its minimum value. Any value within the P26's measuring range can be selected.

7.2.1.3 Units

Use this menu item to select the pressure unit. The following pressure units can be selected:

- Pa
- hPa
- kPa
- mbar
- mmH₂O
- mmHg
- Psi
- inH₂O
- inHg

7.2.2 Volume flow

This menu item is used to adjust the volume flow display values.

The following sub-menu items are available:

- Value
- Units

7.2.2.1 Value

This is used to set the volume flow value displayed at the maximum scaled pressure. 0 is always used as the lower scale value on the volumetric flow display (root-extracted measured value). The maximum pressure is the larger of the two scale values, which is used as a basic calculation.

7.2.2.2 Units

You can use this menu item to select the scaling unit of the volume flow value. This unit don't have to be identical to the selected display unit. The following volume flow units can be selected: m³/s, m³/h and with LVF-Option ft³/h.

7.2.3 Mass flow

This menu item is used to adjust the mass flow display values.
The following sub-menu items are available:

- Value
- Units

7.2.3.1 Value

This is used to set the mass flow value displayed at the maximum scaled pressure. 0 is always used as the lower scale value on the mass flow display (root-extracted measured value). The maximum pressure is the larger of the two scale values, which is used as a basic calculation.

7.2.3.2 Units

You can use this menu item to select the scaling mass flow unit. This unit don't have to be identical to the selected display unit. The following mass flow units can be selected: kg/s, kg/min, kg/h

7.2.4 Flow rate

This menu item is used to adjust the flow rate display values.
The following sub-menu items are available:

- Value
- Units

7.2.4.1 Value

This is used to set the flow rate value displayed at the maximum scaled pressure. 0 is always used as the lower scale value on the flow rate display (root-extracted measured value). The maximum pressure is the larger of the two scale values, which is used as a basic calculation.

7.2.4.2 Units

Use this menu item to select the scaling flow rate unit. This unit don't have to be identical to the selected display unit. The following flow rate units can be selected: m/s, mph, f/s, f/min, km/h

7.3 Air consumption function (option available from firmware version 3.0)



The air consumption function is only available if you have selected one of the following units as the display unit:
m³/s, m³/h, ft³/h, kg/s, kg/min or kg/h.

This function records the consumed volume or mass of the medium being measured. The settings are protected by a separate code. You can change the parameters after entering the correct code. The code remains active until you leave the menu. After switching to the display mode, you must re-enter the code if you wish to change the parameters.

7.3.1 Mode

A number of modes are available for recording the volume(s):

7.3.1.1 Off

Recording of consumption values is deactivated. The scaling function is available.

7.3.1.2 $\Sigma(\Delta P > 0)$

Recording of the quantity consumed only for pressures > 0 . When creep suppression is activated, only pressures greater than the amount of creep will be recorded.

7.3.1.3 $\Sigma(\Delta P)$

Recording of the consumption values also takes negative differential pressures into account. The consumption or mass values calculated from the negative pressures are deducted from the total.

7.3.1.4 $\Sigma(\text{abs } \Delta P)$

In this mode, the sign (+/-) of the differential pressures is not taken into account. In both cases, the consumption or mass value calculated is added to the total.

7.3.2 Mass/Pulse or Vol./Pulse

The recorded consumption values are signalled to the connected control module by a relay. Every pulse corresponds to a defined volume or a definable mass. This menu item can be used to set this volume or mass. The parameter displayed depends on the display units selected. Adjusting the scaling feature adjusts the associated volume or mass value. This enables you to switch between displaying mass and volume readings even while the unit is operating. Values are adjustable between 0.1 and 10000 m³ or kg.



The pulse output can generate a pulse rate of max. 5 pulses/s. Adjust volume/pulse or mass/pulse so that this pulse rate is not exceeded even at the max. flow rate. If the pulse rate is exceeded, the output will continue to pulse even when the section is not sending a signal as it attempts to transmit all the accumulated pulses. Longer periods of activation or inactivity also reduce this pulse rate.

7.3.3 Pulse output

This menu item is used to adjust the pulse length and the min. break for the volume or mass pulses.

7.3.3.1 Pulse length

This parameter is used to defined the duration of the relay pulse. Values are adjustable between 20 and 1999ms.

7.3.3.2 Pulse interval

This parameter is used to define the min. break after a relay pulse. Values are adjustable between 50 and 1999ms.

7.3.4 Filter

Either the filtered or unfiltered value can be used to record the consumption values. Use this setting to select either the filtered or unfiltered value.

7.3.5 Reset sum

This function is used to reset the sum for the consumption function. The last value is saved as backup. (Yes --> Sum = 0, No --> Sum is retained)

7.3.6 Old sum

This menu item is used to display the consumption values sum from before the last reset.

7.3.7 Recall Sum

This function can be used to restore the sum for the consumption function from before the last sum reset. (Yes --> Recall, No -- Current value is retained.)

7.3.8 Security code

This function can be use to set the code for accessing the menu. You should set a security code when the air consumption function is activated in order to prevent the device from being manipulated. When the security code is > 0000, it is only possible to access the menu after entering this security code.

7.4 Warning

Use this menu item to influence the behaviour of the relays. The first menu item that appears here is Select Relay. The settings for this relay should then be changed. Use the “▲” and “▶” keys to select the number of the relay and press Enter to move to that relay's menu. The following sub-menu items are available:

- Mode
- Value
- Hysteresis
- Tv
- Tn
- Warning signal
- Filter

7.4.1 Mode

During normal operation, the relay outputs are used to signal when values rise above or fall below definable pressure limits. This parameter can be used to influence the behaviour of the relays.

The following settings are available:

- Off Relay not active
- Increasing Relay picks up when the warning pressure is exceeded (depends on air pressure)
- Decreasing Relay picks up when the warning pressure is underrun (depends on air pressure)
- Air consumption Relay is used as a pulse output for the air consumption function if this is activated, otherwise the relay is deactivated

Special version Software Rev, 4.01: Here the switching direction of the relays is inverted, that means the relays drop out when the warning pressure is exceeded or underrun.



In "air consumption" mode, the other relay parameters are not used and therefore not displayed in the menu.

7.4.2 Value

This item adjusts the pressure value at which the particular relay should switch. The pressure range defined by the scale can be used as the setting range. Select the pressure unit set for the display as the unit.

7.4.3 Hysteresis

This item can be used to select the hysteresis for the particular relay. If the volume flow, mass flow or flow rate (root-extracted display) is displayed, the pressure unit used will be the unit that was active at the time when the root-extracted display was activated. The hysteresis is always positive and can be set between 0% and 120% of nominal pressure value.

7.4.4 Tv delay time

The entry value of the relays is derived from the unfiltered pressure value. With this parameter, you can now specify how long the pressure value can be exceeded or not met until the relay switches. The adjustment is done in ms.

7.4.5 Tn stopping time (from Rev2.11)

The entry value of the relays is derived from the unfiltered pressure value. This parameter can now be used to specify how long the relay should remain active after the pressure value has returned to the range in which the relay is not activated. The adjustment is done in ms.

7.4.6 Warning signal

A warning signal sounds once every second when a threshold value is exceeded. With this parameter, you can set the duration of this warning signal for each warning. The maximum value here is 1000 ms (continuous tone). If both threshold parameters have been exceeded, both warning tones will sound. In this case, the duration of the warning tone will be equal to the sum of the durations of the two separate tones but max. 1000 ms.

With firmware Rev 2.21 and later, the warning signal can be switched off by pressing any of the front key of the P26. It will be reactivated if the pressure will pass any of the the warning levels again.

7.4.7 Filter(from Rev2.14)

This item can be used to adjust whether the filtered or unfiltered pressure value is used as source for the relay. Depending on the filter time constants, the filtered pressure values can be used to filter out short-lived fluctuations in the pressure level.

7.5 Setting

With this menu item, you can adjust various parameters that affect the instrument's behaviour. The following sub-menu items are available:

- Language
- Output
- Filter
- Touchtone
- Resolution
- Zeroing
- CS (creep suppression)
- Lighting
- Colour change
- Brightness
- Contrast
- Read factory settings
- Code?

7.5.1 Language

The menu language can be selected with this menu item. You can choose from the following languages:

- English
- German
- Italian
- French

Make your choice with the “▲” or “▶” keys. Press Enter to confirm your selection.

7.5.2 Output

With this parameter, you can select the output and output range. You can choose from the following options:

- 4...20 mA
- 0...20 mA
- -5V...+5V
- 0V...10V

7.5.3 Filter

The measured pressure values can be smoothed by a filter before they reach the display or analogue output. This parameter lets you set a time constant for this filter.

7.5.4 Touchtone

This parameter allows the user to switch-on or -off the touchtone.

7.5.5 Resolution

This parameter affects the display resolution. The display is changed according to the adjusted values. For example, if the setting is 1%, the display changes to showing the measuring range in 1% jumps. This can be used with severely fluctuating pressures to steady the display. However, this does not have any effect on the relays.

7.5.6 Zeroing

This parameter specifies the time interval for the automatic zero-point calibration. The entry is in min. The parameter “AutoNull” can be assigned to values from 0 to 2999. Setting the parameter to 0 deactivates automatic zero-point calibration.

7.5.7 SMU (creep suppression)

This parameter specifies the value for creep suppression as a percentage. If this value falls short of the measured pressure value, the display is set to zero. Creep suppression only works with volume flow, mass flow and flow rate (root-extracted measurement values).

7.5.8 Illumination

This parameter can be used to select the backlighting colour for the LCD display in the menu or when the colour change function has been switched off. You can choose from the following three options:

- Off The background lighting is shut-off
- White The background lighting is white
- Blue The background lighting is blue

7.5.9 Colour change

This parameter can be used to specify whether or not the display background should change colour when a threshold parameter has been exceeded. You can choose from the following two options:

- off The colour change function is deactivated
- on The colour change function is activated

When a value specified in the list of warnings is out of range, the display will turn yellow for the time T_v or T_n and then be backlit in red after the relay is triggered.

7.5.10 Brightness

This parameter lets you adjust the brightness of the background lighting. You can adjust the values from 0 (dark) to 16 (bright).

7.5.11 Contrast

This parameter is used to adjust the contrast of the display. This enables you to compensate for different temperatures or viewing angles. Values from 0 (low contrast) and 32 (high contrast) are possible.

7.5.12 Read factory settings

The factory settings are established in the instrument before delivery. With this menu item, they can be reactivated if required.

7.5.13 Code?

You can use this menu item to specify an access code for the menu. If this code is $\neq 0$, the access code will only be queried after the Menu key has been pressed. Only when the correct code has been entered can you proceed to the menu.

If the code = 0, this query will not be made.

7.6 Operation

The operating hours meter displays the recording period for the current air consumption function. When the air consumption sum is reset to zero, the operating hours meter is also reset to 0 h.

8 Interfaces

8.1 USB port (optional)

The USB interface incorporates a USB socket with an integrated USB-to-serial converter. For this, the driver from the manufacturer FTDI must be installed on the PC.

Please visit the manufacturer's website: www.ftdichip.com

<http://www.ftdichip.com/Drivers/CDM/CDM 2.08.24 WHQL Certified.zip>

Under DRIVERS / VCP DRIVERS, select the appropriate driver for your operating system. Once installed, the driver will set up an additional virtual COM port.

8.2 Serial interface (via internal connector)

The serial interface (RS 232) has the following settings:

- 9600 baud
- 8 data bits
- no parity
- one stop bit

8.3 List of commands

Command	Description	Model	Rev.
?IP	Displays the current pressure in the selected unit (see command UnitD)	floating	
?ST	Displays the status: Bit6: Relay1 switched Bit5: Relay2 switched Bit2: Pressur overload Bit1: zeroing activated Reserve bits: 7, 4, 3, 0	8-digit	
?Rev	Query of the device revision (from Rev. 2.11)	P26 Rev.: 2.xx	
?DMB	Measurement range (from Rev. 2.11)	floating	
SaveSet	Saving parameters	-	
RecallWE	Load default settings	-	
MZ	Mode Zero-Point Calibration	-	

Parameters	Description	Model	Rev
Set: '>'par			
Query: '?par			
ScalO	Scale top [Pa] (-120% .. 120% of the measurement range)	floating	
ScalU	Scale bottom [Pa] (-120% .. 120% of the measurement range)	floating	
ScalVS	Volume flow [m ³ /s] at max. scale value (ScalO) (Min: 0)	floating	
ScalMF	Mass flow [kg/s] at max. scale value (ScalO) (Min: 0)	floating	
ScalSG	Flow rate [m/s] at max. scale value (ScalO) (Min: 0)	floating	
PRelai1	Switching pressure relay 1 [Pa] (-120% .. 120% of the measurement range)	floating	
RRelai1	Switching direction for Relay 1 (-1 = decreasing, 0 = off, 1 = increasing, 2 = air consum.)	int	
SRelai1	Sound for Relay 1 [ms] (0 = Off, 0 ..) 1000)	unsigned int	
HRelai1	Hysteresis relay 1 [Pa] (0 .. 120% of the measurement range)	floating	
TRelai1	Response time for relay 1 [ms] (0 .. 30000)	unsigned int	
ARelai1	Dropout delay for relay 1[ms] (from Rev. 2.11) (0 .. 30000)	unsigned int	
RFilter1	Selects the input pressure for relay 1 (0 = unfiltered, 1 = filtered)		
PRelai2	Switching pressure relay 2 [Pa] (-120% .. 120% of the measurement range)	floating	
RRelai2	Switching direction for relay 2 (-1 = decreasing, 0 = off, 1 = increasing, 2 = air consum.)	int	
SRelai2	Sound for relay 2 [ms] (0 = Off, 0 ..) 1000)	unsigned int	
HRelai2	Hysteresis relay 2 [Pa] (0 .. 120% of the measurement range)	floating	
TRelai2	Response time for relay 2 [ms] (0 .. 30000)	unsigned int	
RFilter1	Selects the input pressure for relay 1 (0 = unfiltered, 1 = filtered)		

Parameters	Description	Model	Rev
ARelai2	Dropout delay for relay 2 [ms] (from Rev. 2.11) (0 .. 30000)	unsigned int	
Filter	Step response time (T63) [ms] (25 .. 60000)	unsigned int	
Lang	Language (1=GB, 2=GER, 3=I, 4=F)	unsigned int	
AutoNull	Automatic zero-point calibration [min] (0=Off, 0 ..) 2999)	unsigned int	
Sound	Sound (0=Off, 1=On)	unsigned int	
TSound	Sound duration [ms] (0 .. 999)	unsigned int	
DAC Out	Analogue output signal (0 = 4 .. 20mA, 1 = 0 .. 20mA, 2 = -5 .. +5V, 3 = 0 ... 10V)	unsigned int	
Res	Resolution (0=max., 1=0.01%, 2=0.1%, 3=0.2%, 4=0.5%, 5=1%)	unsigned int	
UnitD	Unit display (0=Pa, 1=hPa, 2=kPa, 3=mbar, 4=mmH2O, 5=mmHg, 6=Psi, 7=inH2O, 8=inHg, 9=m³/s, 10=m³/h, 11=kg/s, 12=kg/min, 13=kg/h, 14=m/s, 15=mph, 16=f/s, 17=f/min, 18=km/h)	unsigned int	
>Code	Access code for the menu (no reading) (0 .. 9999)	unsigned int	
SMU	Creep suppression [%] (0.0 ... 10.0)	floating	
C-Change	Colour change (0 = off, 1 = on)	unsigned int	Lrg. disp
Contrast	Contrast setting (0 ... 32)	unsigned int	Lrg. disp
Brightn.	Brightness of backlighting (0 ... 16)	unsigned int	Lrg. disp
B-Light	Backlighting (0 = off, 1 = white, 2 = blue)	unsigned int	Lrg. disp
	Air consumption function '>' only when the correct code has been entered		
LVF_Mode	0 = off deactivated 1 = $\sum(\Delta P > 0)$ sum for P > SMU 2 = $\sum(\Delta P)$ sum with correct prefix 3 = $\sum(\text{abs } \Delta P)$ sum absolute	int	3.0
VInc	Volume per relay pulse [m³,ft³]	floating	3.0
MInc	Mass per relay pulse [kg]	floating	3.0
LVF_Puls	Duration of the relay pulse [ms] 20 ... 2000	unsigned int	3.0
LVF_Pause	min. break after a relay pulse [ms] 50 ... 2000	unsigned int	3.0
LVF-Filter	Pressure source 0 = unfiltered, 1 = filtered		
?LVF-Code	Enter password for the LVF functions If confirmed, the LVF status is send as an echo	4 digit decimal	3.0
>LVF-Code	Enter password for the LVF functions	4 digit decimal	3.0
?LVF	Current air consumption value dep. on unit	floating	3.0
?LVF_V	Display the current LVF volume value	floating	3.0
?LVF_M	Display the current LVF mass value	floating	3.0
?LVF_V_alt	Display the old LVF volume value	floating	3.0
?LVF_M_alt	Display the old LVF mass value	floating	3.0
>LVF_Res	Set LVF value to 0		3.0
>LVF_Rcl	Reset LVF value to old value		3.0
?LVF_Rel	Query LVF relay (1 = Rel1, 2 = Rel2)	unsigned int	3.0

Parameters	Description	Model	Rev
?LVF_Stat	Status LVF_Function Bit 0 = LVF function available Bit 1 = LVF capable display unit is selected Bit 2 = LVF data is correct Bit 3 = LVF data is read-out Bit 7 = entered LVF code is correct		
?LVF_Unit	Display the unit of the LVF function = (displayed unit-9) 0,1 = m ³ ,2 = ft ³ , 3,4,5=kg	int	3.0
?LVF_Inc	Read-out mass or volume increment per pulse depending on the selected unit	floating	3.0
?Betrieb	Read-out operating hours meter	floating	3.0
Ser.Nr	Serial number xxxx	int	3.0
P-Date	Production date jjmm	int	3.0
>ALZ	Set to delivery condition		3.0
SaveSet	Save settings		
RecallWE	Memorise default settings		

9 Technical data

Measurement data	
Measurement range (also ± measurement ranges)	10 / 50 / 100 / 250 / 500 Pa 1 / 2.5 / 5 / 10 / 20 / 50 / 100 kPa (freely scalable from 10 to 100% within a measurement range)
Measurement accuracy (at 20°C; ±2°C)	± 0.2 % FS (for measurement ranges ≤ 50 kPa) or ± 0.5 % FS (0.3 Pa margin of error for the reference)
Resolution	dependent upon measurement range (max. 5 significant digits)
Ambient conditions	
Medium	Air, non-aggressive gases
Operating temperature	+10 °C to +50 °C
Storage temperature	-10 °C to +70 °C
Protection class	IP65/ USB-version IP40
Certifications	CE / UKCA
Electrical data	
Power consumption	approx. 6 VA
Supply voltage	see rating plate 24VAC/DC +/-10% 24VAC(with galvanic separation) +/-10% 230/115VAC +/-10%
Output signal	0 ... +10 V ($R_L \geq 2 \text{ k}\Omega$) or -5 ... +5 V ($R_L \geq 2 \text{ k}\Omega$) or 0 ... 20 mA ($R_L \leq 500 \Omega$) or 4 ... 20 mA ($R_L \leq 500 \Omega$)
Relay	
2 x changeover contacts	6 A / 230 VAC each
Interfaces (optional)	
RS-232	9600 baud, 8 data bits, no parity, one stop bit
USB	12 Mbps USB 2.0 Full-Speed

10 Troubleshooting

Problem	Cause	Corrective Action
Instrument does not work; nothing on display	No power	Check the terminal connections and supply voltage
Only m ³ /s, m ³ /h, ft ³ /h, kg/s, kg/min and kg/h may be used as display units.	Air consumption function activated.	Delete consumption sum and deactivate air consumption function.
Scaling menu does not appear in the menu	Air consumption function activated.	Delete consumption sum and deactivate air consumption function.
Air consumption function does not appear in the menu	Incorrect display unit. Only m ³ /s, m ³ /h, ft ³ /h, kg/s, kg/min and kg/h may be used with this function.	Please select the correct display unit
Air consumption function does not appear in the menu	Air consumption deactivated	Please contact manufacturer
„Na“ is displayed as current value	Wrong settings for scale	Change scale
Pressure drops continuously	Leak	Firmly slide tubing completely onto ports; adjust diameter
No serial communication	No cable connection	Make sure cable is connected securely

11 Dimension drawing

P26 with display

P26 without display

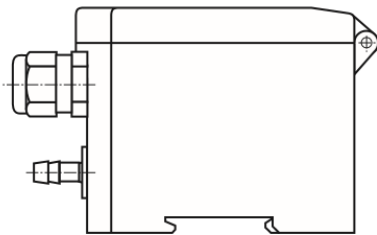
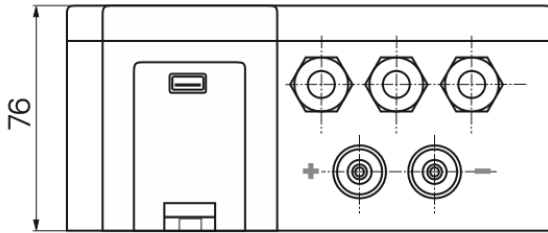
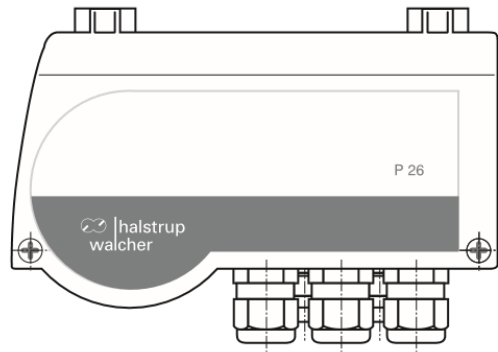
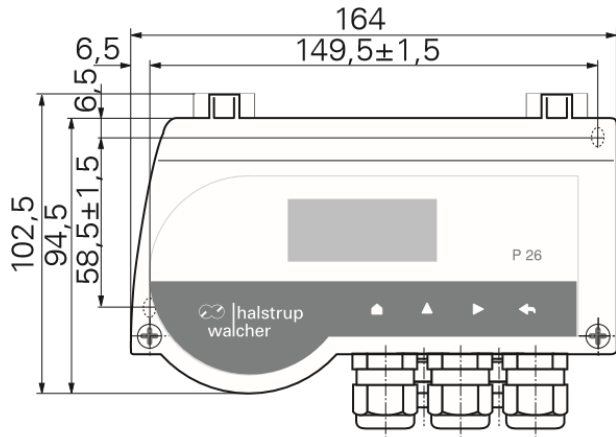

12 Menu tree

Level 1	Level 2	Level 3	Level 4
Display	Pressure	Pa	
		hPa	
		kPa	
		mbar	
		mmH2O	
		mmHg	
		psi	
		inH2O	
		inHg	
		m ³ /s	
		m ³ /h	
		kg/s	
		kg/min	
		kg/h	
		m/s	
		mph	
		ft/s	
ft/min			
km/h			
ft ³ /h(LVF option)			
Scale	Pressure	Top	xxx.xx)*
		Bottom	xxx.xx)*
		Unit	Pa
			hPa
			kPa
			mbar
			mmH2O
			mmHg
			psi
			inH2O
		inHg	
	Volume flow	Value	xxx.xxxx)*
		Unit	m ³ /s
			m ³ /h
	Mass flow		ft ³ /h
		Value	xxx.xxxx)*
		Unit	kg/s
		kg/min	
Flow rate		kg/h	
	Value	xxx.xxxx)*	
	Unit	m/s	
		mph	
		ft/s	
		ft/min	
		km/h	

Level 1	Level2	Level3	Level4	
Consumption	Mode	Off		
		$\Sigma(\Delta P >0)$		
		$\Sigma(\Delta P)$		
		$\Sigma(\text{abs } \Delta P)$		
	Mass/pulse			
		Vol./pulse		
		Pulse output		
			Pulse duration	xxxx ms
			Pulse interval	xxxx ms
	Filter		On	
			Off	
		Sum reset	Yes/No	
		Old sum		
		Recall Sum	Yes/No	
	Security Code	xxxx		
Warning	Relay1			
	Relay 2			
		Mode	Increasing	
			Decreasing	
			Off	
			Air consum.	
		Value	x.xxxx)*	
		Hysteresis	x.xxxx)*	
		Tv	xxxxx ms	
		Tn (Rev2.11)	xxxxx ms	
		Warning signal	xxxx ms	
		Filter (Re2.14)	Off, on	
	Setting	Language	English	
German				
Italian				
French				
Output		4 ... 20 mA		
		0 ... 20 mA		
		-5 ... +5V		
		0 ... 10 V		
		Filter	xxxxx ms	
Touchtone		On		
		Off		
Resolution		max.		
		0.01%		
		0.1%		
		0.2%		
		0.5%		
		1%		
		Zero-point calibr.	xxxx min	
	SMU	x.x%		

Level 1	Level 2	Level 3	Level 4
	Lighting	Off	
		White	
		Blue	
	Colour change	On	
		Off	
	Brightness	0 ... 16	
	Contrast	0 ... 32	
	Read factory settings	(Yes = press Enter)	
	Security Code?	xxxx	

)* Decimal point depends on selected unit

For additional specifications and dimension drawings, please visit our website at

www.halstrup-walcher.de/en/products/measurement-technology/



13 Certificates of Conformity



Die Lösung liegt im Detail

EG-Konformitätserklärung im Sinne der
EG- Richtlinie 2014/30/EU, EMV Richtlinie und
2006/95/EG, Niederspannungsrichtlinie

Certificate of Conformity based on the
European Standard 2014/30/EU, and 2006/95/EG

Der Hersteller
The manufacturer

**halstrup-walcher GmbH
Stegener Straße 10
79199 Kirchzarten
Deutschland**

erklärt, dass die Bauart des Produktes
declares, that the construction of instrument type

**Differenzdruck-Messumformer Typ P26
Differential Pressure Transformer Type P26**

entwickelt, konstruiert und gefertigt ist in Übereinstimmung mit den EG – Richtlinien
is developed, designed and manufactured in accordance with the EC Directives.

EN 61000-6-2 : 2005
EN 61000-6-4 : 2011
EN 61010-1 : 2011

abgegeben durch / stated by:

Sura, Christian
(Nachname, Vorname / Surname, first name)

Geschäftsführer, Managing Director
(Stellung im Betrieb des Herstellers / Position)

Kirchzarten, 19.10.2016
(Ort, Datum / City, Date)

(Rechtsgültige Unterschrift/ Signature)



UK Declaration of Conformity

Company halstrup-walcher GmbH, Stegener Str. 10, 79199 Kirchzarten
declares as manufacturer under sole responsibility, that the product

Product Differential pressure transmitter type
P26

Regulations is in conformity with relevant statutory requirements:

LVD	Electrical Equipment (Safety) Regulations 2016 No. 1101
EMC	Electromagnetic Compatibility Regulations 2016 No. 1091
RoHS	RoHS Regulations 2012 No. 3032

Standards applied standards:

EN 61010-1:2010
EN 61000-6-2:2005
EN IEC 63000:2018

Declaration signed for and on behalf of



Managing Director
Kirchzarten, 8. Jul.2022

